



www.ijatir.org

Freighter Fuel Level detection and Overload System with Safety Notification via GSM

MD. MUBIN¹, C. MADHUSUDAN²

¹PG Scholar, Dept of ECE, Aryabhata Institute of Technology and Science, Hyderabad, India.

²Asst Prof, Dept of ECE, Aryabhata Institute of Technology and Science, Hyderabad, India.

Abstract: A PIC microcontroller based digital electronic system has been designed to monitor the fuel level and total amount of load on the freighter and generate scan report for the captain of the freighter. The system is designed for three different freighter load levels; no load, optimal load and over load. At initial level it remains in no load status, when load increases and still remain in optimal level then the system notify crews to initiate voyage. If the load increases to over load level then the system gives alarm and sends alert message to the main control tower for necessary initiative. The communication between the vessel and main control tower is done by GSM module to ensure long distance reliable communication. For amenity, freighter fuel level is monitored in both analogue and digital scale. The system is implemented by PIC midrange microcontroller based hardware and low cost GSM module which makes it more economic, reliable and efficient

Keywords: Freighter; Fuel Level, PIC Microcontroller, GSM, Overload Alarming.

I. INTRODUCTION

Freighter is a cardinal part for the transport, especially for the inland, inshore and seaward navigation system. It provides a better alternative to other modes of transport by being energy efficient and reliable since it can carry large number of people and goods at the same time. Especially for the lower land and populated countries like Bangladesh, India, Maldives, Indonesia etc; it becomes an inevitable part for the transport system. By carrying goods inside and outside the country it is contributing a lot to the economy. So it is a major concern to make the freighter based transportation system more safe and reliable. But some hazardous incidents in recent years have instigated the researcher to make the system more reliable. In a report it has been seen that only in Bangladesh around 3869 people have been died since 1976 by water vessel hazard [1] and in US around 651 people have been died in the year 2012 [2]. A case study reveals that about 80 per cent of the accidents occurring at water body were the result of human errors [1]. The major cases for hazards are excessive speed, failure of ventilate, operation inexperience, operation inattention, navigation rules violation, improper anchoring, improper loading, machinery failure, electrical system

failure, fuel system failure, boisterous weather etc. A case study reveals that about 25 per cent of the causes of sinking of freighter or water vessel are for overloading [2].

In low income, populated and lower land country, overcrowding is the major factor for overloading accident. Most of the overloading cases indicate that the vessels were loaded as many as 3-5 times of their capacity. On the other hand, maximum boat sailors are not concerned about freighter loading condition and fuel level. Most of these level sensing are analogue or a personnel is engaged to monitor loading and fuel level. Besides, it's a boring and difficult task to check the fuel level frequently in running condition. Sometimes if the bilge pump seems to be working overtime it may result vessel to be filling with water and seems to feel heavy. So in this research, the soul idea and motivation is to design a system to avoid freighter hazard due to overloading and lacking fuel level surveillance. Since the system is digital, it requires no personnel to monitor fuel level and water level again and again on running condition. The system will work automatically according to the load and in any hazard condition it will give alert alarm and send notification message and call to the central ship monitoring unit for necessary initiative.

Moreover, for overloading, high pressure falls on engine which may cause degradation of engine performance. Overloading alert can save this degradation. When optimal loading occurs it generates sound to inform the passengers that the vessel is secured with loading and ready for voyage and signal lights gives notification in sailor room to start the freighter. By this system, freighter fuel level can be monitored in both analogue and digital scale with greatest flexibility to take necessary steps in any condition. So, if for any reason digital system fails, the mechanical niddle and pointer system shows the fuel level on display. In most of the luxurious freighters, different system like this is integrated, but for the low cost freighter for developing countries such device is not commercially available as separate device to use in all kinds of boat. The system has a scope to implement solar power as auxiliary power supply if main supply fails. The proposed system is implemented by the economic electronic circuitry and

based on GSM so that easily can retain reliable communication between the freighter and the central monitoring unit from far distance.

II. SYSTEM DESIGN

The system is designed with the PIC microcontroller and the GSM module. Microcontroller based electronic system monitors the total amount of load on the vessel and sends safety notification and alarm to the concerned authority for necessary initiative. At normal loading condition the system sends the safety notification to the concerned crew to initiate voyage. In case of any hazardous conditions like over loading or over flooding, the system turns to alarming mode and notifies the captain and the other concerned crews of the ship by alert alarm. If the fault is made clear by the crews and the ship become out of danger then the system automatically turns back to monitoring mode. But if the fault is not cleared and the danger level rises, the system generates a massive caution alarm and notifies the control tower by sending an alert message and making phone call to the control tower. A serial GSM MODEM serves as the communication channel between the electronic system and the control tower. Side by side the freighter load surveillance, fuel level is also monitored. A specially designed sensor is placed in the fuel tank to detect the fuel level. This sensor is connected with an analog indicator as well as with the microprocessor unit to get the fuel level indication in digital scale. Overall, the design of the system may be divided in three parts. Firstly, basic model has been designed with block diagram, secondly corresponding circuitry has been analyzed and finally necessary firmware with software has been designed for the practical implementation.

A. Block Diagram

A block diagram has been depicted for the whole system in the following figure 1.

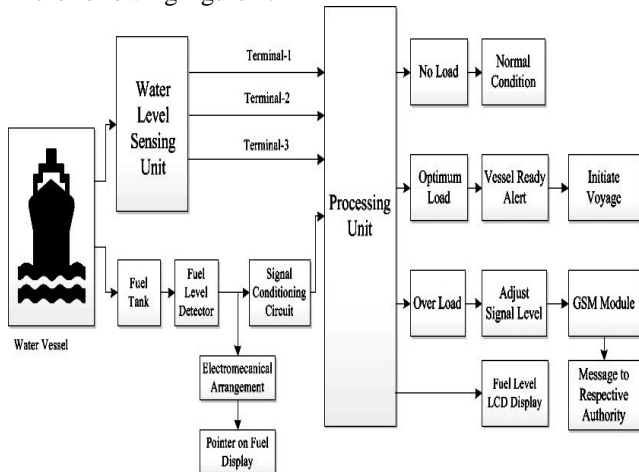

Figure1. Block diagram of the system.

A water level sensing unit has been designed to sense the water level which sends the signal to the microprocessor unit. Depending on the load the water vessel is

categorized into three levels; no load level, optimum load level and overload level. According to the sensor information at initial level, a green light connected with the microprocessor unit remain on to show safety load, at optimum loading condition sensor gives signal to microprocessor and finally safety notification goes to concern to initiate safe voyage, at overload level microprocessor gives signal to the alarm for the safety notification and also to GSM module via MAX 232 for sending information to the central freight monitoring unit. A fuel level sensing unit is also designed to fix with fuel tanker. For convenience, it has been designed to give both analogue and digital fuel level indication. Analogue indication system is set near the sensor and fuel tanker. A connection from the fuel level sensing unit has been connected with the microprocessor unit and from the microprocessor unit a LCD display is connected from which digital fuel level indication is displayed.

B. System Circuit Diagram

Total system circuit diagram has been illustrated in the figure 2. According to load status of the freighter, load sensor has been designed specially. In the following figure 2, three sensors named A, B, C for no load, optimal load and overload sensors accordingly.

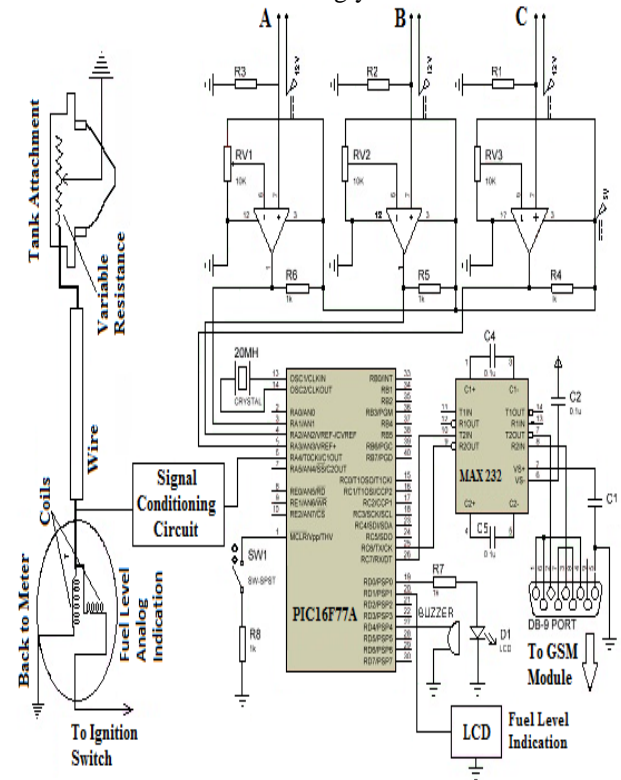

Figure 2. Circuit diagram of the system.

The output of the sensors is then conditioned by simple voltage comparator circuits based on LM 339 IC. The output of the conditioning circuit is then fed to the microcontroller. Microcontroller reads the sensor states and classifies the danger level of the vessel. For alarming,

Freighter Fuel Level detection and Overload System with Safety Notification via GSM

an alarming buzzer, indicating LED and a GSM modem is interfaced with the microcontroller. Microcontroller communicates the MOD 9001 GSM modem using UART (Universal Synchronous Asynchronous Receiver Transmitter) where MAX 232 voltage level converter is used in order to match the communication voltage levels between the two devices [3]. The power supply for all these devices are designed such it can provide up to 3 ampere current at 12 volts. A fuel level detection sensor is also connected with the circuit to measure the fuel level. It is basically based on resistor. According to the resistive value and fuel level there is a variation of corresponding voltage and current on the sensor circuit. This voltage variation is standardized with a signal conditioning circuit and connects with a microcontroller. From the microcontroller a LCD display is connected to read the sensor indication is digital scale to comprehend the fuel level.

C. Water Level Sensing Unit

To make the system user friendly, water level sensing unit is designed avoiding complexity. This sensor works on the basis of water resistivity. When the vessel is without load, a certain part of its bottom body remain under water which gives a fixed water level. After loading passengers the water level rises as weight increases according to Archimedes theory [4]. The rising level is confined for normal passenger load. When the vessel is overloaded the water level rises more than the level confined for normal passenger load. Based on this concept, water sensor is made which has three open terminal wires along with other necessary circuitry. One terminal is fixed at no load water level which has marked as A in the figure 2. This is in normal water level and designed in such a way when no passenger on the ship. Other two terminals are kept fixed at two different overloaded water level positions which have been marked as B and C in the figure 2. Sensor B is designed in such a way when the ship is fulfilled with passengers or goods and green light remain on to show safety. The overload indicating sensor C is designed in such way so that the system responses by massive alarm and safety notification. Basically when the respective third terminal of the sensor comes into contact with water the related circuitry comes into operation, which alarmed that the vessel is in over loaded condition.

D. Safety Notification Processing

A GSM based system is interfaced with this circuitry to transmit freighter loading information to a responsible authority. When the water level sensor's respective third terminal comes into contact with water the related circuitry comes into operation and a signal goes to microprocessor unit from the sensor, finally which enables the GSM module send notification SMS to the respective authority. The GSM is connected to the microcontroller through a USART communication circuit consists of MAX 232 and RS 232 port [5].

E. Fuel Level Detection

A fuel level indication unit has been designed in the following figure 3 [6]. The fuel level sensor of this system is designed by fuel gauge which is installed on water vessel fuel tank to determine the level of gasoline or other type of liquid fuels [6]. This detector has mainly two units, sensing and indicator unit. Sensing unit is usually mounted inside of fuel tank consists of float connected with an arm which varies the resistive value of an electrical circuit placed outside of the tank. The indicator unit is either electro-mechanical analog system or digital system ensured by processing unit, microcontroller. When fuel level is empty in the tank, float moves the arm in such a way that the resistance of the circuit will get maximum value which results lower value of current. On the other hand, when the fuel tank is full, the fuel circuit detects minimum resistance, hence maximum current flows [6]. This output current is taken as input of indicator unit.

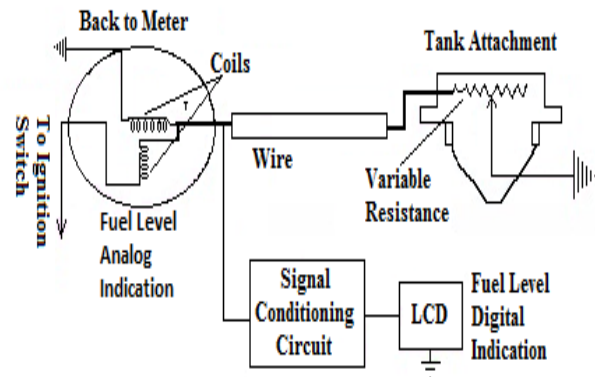

Figure3. Sensing and indication unit of fuel level detection.

This proposed system includes combination of both analog and digital indicator system. For digital operation, output signal goes to microcontroller through a signal conditioning circuit consists of an amplifier and analog to digital converter (ADC). Depending upon float level in tank, microcontroller determines the actual fuel level which can be displayed on liquid crystal display (LCD) screen. On the other hand, for electromechanical analog operation, prior going to signal conditioning circuit, current signal pass through a to a light weight magnet which is pivoted about the centre. A pointer is being attached with magnet, as the magnet rotates pointer swings as well. When the tank is empty, least current flow in the fuel circuit unable to swing the needle of the fuel gauge, thus needle is unmoved, hence it points on empty position. Mechanical operation is caused by two coils which form electromagnets, one is horizontal other coil is vertical shown in figure 3. As the coils are energized, one coil is trying to swing the pointer full position the other is holding the pointer at empty. Any change in the strength of the magnetic field created by the horizontal coil will cause the pointer to move relative to the strength of other coil. Variable resistor of fuel circuit can be shorted out along its

length depending on fuel level in tank [6]. When the tank is full it effectively shorts out resistor and the magnetic effect of the vertical coil is removed as well as the pointer swings to its fullest amount.

III. HARDWARE DESIGN

To reduce the unnecessary complexity, some simple and commercially available circuitry has been used in this system.

A. Central Microprocessor Unit

PIC 16F877A microcontroller has been chosen as the central microprocessor unit of this system. This microcontroller is superior to other 8 bit microcontroller for its speed and code compression [7]. It has 40 pin with 33 of I/O path. It has 8192 bytes FLASH memory and for this it can write or erase thousand times and easily can be programmed according to the system or customer desire [8]. It also has 156 bytes EEPROM data memory and 368 bytes SRAM data memory: 368 bytes. It also has eight channels of 10 bits each analogue to digital converter (ADC) so that the analogue sensors signal can be connected easily with that [7]. Basically for low cost and commercially availability makes it attractive to chose as main processing unit. Moreover, all necessary peripherals are already built into it so it saves time, space and cost.

B. GSM Module

A GSM modem has been used to send message from the vessel to the main monitoring unit. It sends and receives data through radio waves so that easily can communicate from far distance vessel to the main monitoring room. Generally, AT commands are used to control modems. Reading of message from the SIM card inserted into the modem is done by sending the appropriate AT command to the modem. In addition to the standard AT commands, GSM modems support an extended set of AT commands. These extended AT commands are defined in the GSM standards [9].

Table I. Some Commands Used in Gsm Data Transfer Module of The System

AT Command	Meaning
+CMGI	Module ok
+CMGS	Send message
+CMGW	Write message to memory
+CMGD	Delete message
+CMGC	Send command
+CMSS	Send message from storage

C. Microprocessor Unit and GSM Module Interface

To interface between the microprocessor unit and the GSM module of the system, RS 232 and MAX 232 has been used. MAX 232 converts signals from an RS-232 serial port to signals suitable for use in TTL compatible

digital logic circuits [9]. In the system MAX 232 is a dual driver/receiver and converts the RX, TX, CTS and RTS signals. It includes a capacitive voltage generator to supply EIA 232 voltage levels from a single 5 volts supply. Each receiver converts EIA 232 inputs to 5 volts TTL or CMOS logic levels. Each driver converts TTL or CMOS input levels into EIA 232 levels [10]. GSM Modem, which works at RS 232 voltage levels, logic 1 varies from -3 to -15 volts and logic 0 from +3 to +15 volts. The microcontroller which works on TTL logic levels, logic 1 is +5 volts and logic 0 is 0 volts. Therefore to interface the two, a MAX 232 driver IC has been used [10]. These parts are especially useful in battery-powered systems, since their lowpower shutdown mode reduces power dissipation to less than 5 micro watts. In this system, RS 232 data is bi-polar +3 to +12 volts indicates an "ON" or 0 state (SPACE) condition, while -3 to -12 volts indicates an "OFF" or 1 state (MARK) condition [11] [14]. The output signal level usually swings between +12 to -12 volts. The dead area between +3 to -3 volts is designed to absorb line noise.

D. System Power Supply Unit

The system power supply is specially designed. It is designed considering the large vessel power system. The system has taken power from the main power system of the vessel as the auxiliary component power. So the system doesn't need any costly extra battery arrangement. A rectifier has been designed to converter main vessel power to system adaptable power. To regulate the voltage, an IC LM 7805 voltage regulator has been used [12].

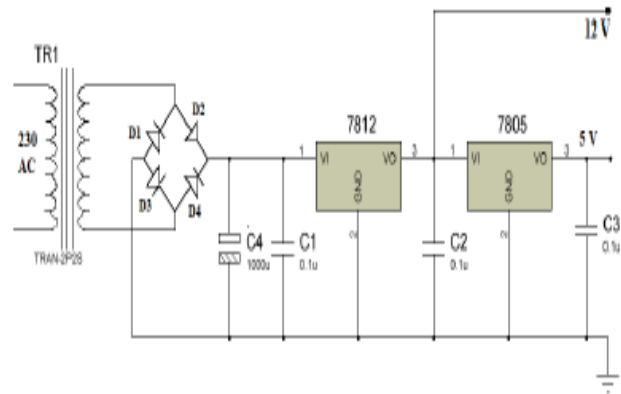

Figure 4. System power supply.

IV. SOFTWARE SECTION

A flowchart to design the system software algorithm has been depicted in the following figure 5. The firmware of the system is developed using high level programming language for microcontroller platform. "MikroC Pro for PIC" compiler supported the firmware development by providing useful built-in routines and flexibility in writing code for microcontroller using C language [13]. In application, the firmware continuously monitors the sensor states and takes necessary actions according to the flowchart in figure 5

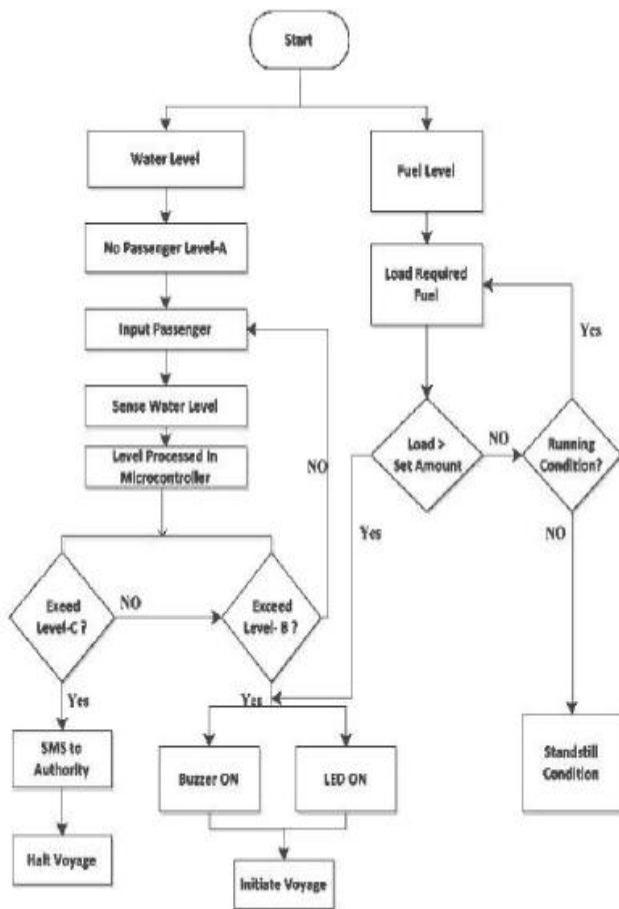

Figure 5. Flow chart to design the software algorithm.

V. PERFORMANCE EVALUATION AND PRACTICAL IMPLEMENTATION CONSIDERATION

In this paper, water level monitoring unit within the context of electrical resistivity of the water is introduced. Resistivity and conductivity are reciprocal to each other. As electrical conductivity increases in presence of salt, so the performance may differ for sea water and river water. The designed water level sensor system depends on the vessel capacity as well as number of passengers. As the vessel size increases the range of sensor operation capacity increases. That means difference between the levels A, B and C increases. The forecasting part consists of GSM module which uses the local mobile network. When dangerous situation is detected, it sends SMS to a pre-programmed mobile number which is permanently set to the microcontroller. The system is designed for large water vessel, which has its own power generation system. So this power supply may replace by a 12 volts battery which is rechargeable by solar panels [15]. Then this developed system can be applied vastly to all kinds of water vessels which do not have their own power system. Considering cost compensation and portability of system, the above features made this system an effective solution for overload alarming and safety notification forecasting system for water vessels.

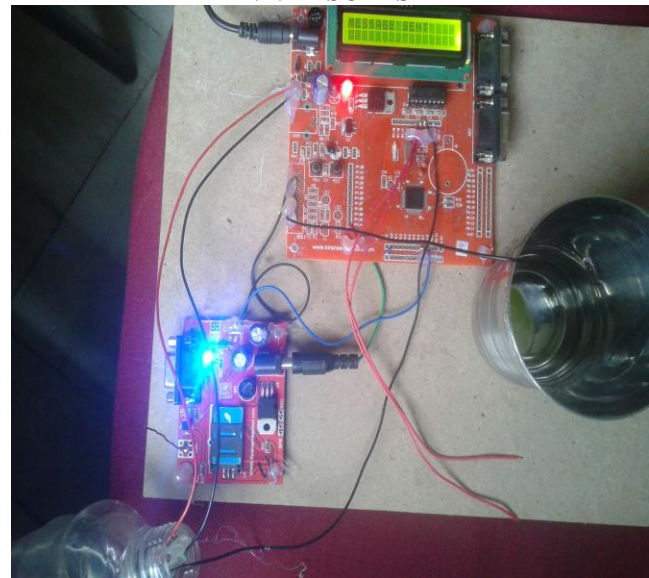

Fig.6. Water Level Exceeds the Limit.



Fig.7. Fuel level exceeds the limit.

VII. CONCLUSION

The proposed system works very effectively until it is physically damaged within a certain GSM coverage network area. Cheap electronic equipments are used to make the system economical. It works automatically without any sophisticated operating command, so it is very user friendly to freighter sailor or crew. But when vessel is running, it may create some problem to get assigned GSM network. So notification message sometimes may create error to reach to control authority. For this a powerful GSM with variety network accessing should be added. Impurity of fuel or salinity of water can reduce the performance of the sensors of the system. Besides adding Temperature Sensors, Tacho Sensor, Pressure Sensor can improve the performance of the proposed system.

Moreover According to the situation and vessel design some components of the detection system may need to change, but the overall design algorithm will remain same. The auxiliary power system to run the system may replace by the solar power in future to get better performance in less cost.

VIII. REFERENCES

- [1] Abul Kalam Azad, "Riverine Passenger Vessel Disaster In Bangladesh: Options For Mitigation And Safety", Dissertation for the Degree of Master in Disaster Management, BRAC University, Dhaka, Bangladesh, 2009
- [2] Paul F. Thomas, "Recreational boating statistics 2012", United States Coast Guard, US, 2012
- [3] Iovine, John. PIC microcontroller project book. McGraw-Hill, Inc., 2004.
- [4] Kazkaz, Ghaffar, Richard C. Francke, and Bradley S. Beiermann. "Resistive fluid level sensing and control system." U.S. Patent No. 6,634,229. 21 Oct. 2003.
- [5] Yuchun, Ma, Huang Yinghong, Zhang Kun, and Li Zhuang. "General application research on GSM module." In Internet Computing & Information Services (ICICIS), 2011 International Conference on, pp. 525-528. IEEE, 2011.
- [6] Deep Gupta, Brajesh Kr. Singh and Kuldeep Panwar. "A Prototyping Model for Fuel Level Detector and Optimizer." African Journal of Basic & Applied Sciences, ISSN 2079-2034, Volume: 4 (6), 2012.
- [7] Mahmud, Khizir, Md Alam, and Rakesh Ghosh. "Design of digital thermometer based on PIC16F77A single chip microcontroller." Consumer Electronics, Communications and Networks (CECN), 2013 3rd International Conference on. IEEE, 2013.
- [8] Khizir Mahmud, Md. Shamsul Alam, Ali Jobayer. "Design and Performance Evaluation of PIC16F77A Microcontroller Based Fluid Velocity Meter." 2013 IEEE Global High Tech Congress On Electronics (GHTCE 2013), IEEE, 2013.
- [9] MA, Shibao, Guoyu Zhang, Xiangyang SUN, Yujun GAO, and Weiwei WANG. "Design of the System of Wireless Alarming Based on GSM Module [J]." Journal of Changchun University of Science and Technology (Natural Science Edition) 1 (2009): 018.
- [10] Jayasinghe, Gamini, Farazy Fahmy, Nuwan Gajaweera, and Dileeka Dias. "A GSM alarm device for disaster early warning." In Industrial and Information Systems, First International Conference on, pp. 383-387. IEEE, 2006.
- [11] Kwah, Zai Shyong. "Gsm Based Remote Terminal Unit Of The Flood Warning And Control System." Diss. University of Bradford, 2010.
- [12] Hargadon, Andrew, Steven J. Young, Kihachiro Tonomura, Markus Wallgren, and Mark Gurries. "Power supply and battery charger." U.S. Patent 5,420,493, issued May 30, 1995.
- [13] Smolnikar, Miha, and Mihael Mohorcic. "A framework for developing a microchip PIC microcontroller based applications." WSEAS Transactions on Advances in Engineering Education 5, no. 2 (2008): 83-91.

- [14] Siang, Beh Kok, A. R. Bin Ramli, V. Prakash, and S. A. R. Bin Syed Mohamed. "SMS gateway interface remote monitoring and controlling via GSM SMS." In Telecommunication Technology, 2003. NCTT 2003
- [15] Khizir Mahmud, Sayidul Morsalin and Md. Imran Khan. "Design and Fabrication of an Automated Solar Boat." International Journal of Advanced Science and Technology (IJAST), Vol- 64, pp. 31-42, 2014.

Author's Profile:



MD.Mubin, PG Scholar, Dept of ECE, Aryabhata Institute of Technology and Science, Hyderabad, India, E-mail: mohammedmubin90@gmail.com.



C. Madhusudan, Assistant Professor, Dept. of ECE, HOD, Aryabhata Institute of Technology and Science, Hyderabad, India, E-mail: madhusudan.gnit@gmail.com.